



HELIUM

FRAME PASSPORT

TYPE: 7DE

LAST UPDATE: 31/10/2012

INDEX

0.	UPDATES	3
1.	GENERAL	3
1.1.	DESCRIPTION	3
1.2.	PART CODES	3
2.	MATERIAL	3
3.	WEIGHT	3
3.1.	FRAME	3
3.2.	FORK	3
4.	GEOMETRY	4
5.	CABLE ROUTING	4
5.1.	COMPATIBILITY	4
5.2.	MECHANICAL CABLE ROUTING	4
5.3.	ELECTRONIC CABLE ROUTING	5
6.	PARTS	5
6.1.	FORK	5
6.1.1.	MATERIAL	5
6.1.2.	DIMENSIONS	5
6.1.3.	WHEELS	6
6.1.4.	PART CODES	6
6.2.	HEADSET	6
6.3.	SEAT POST	6
6.4.	BOTTOM BRACKET	6
6.5.	BRAKES	7
6.6.	DERAILLEUR	7
6.6.1.	FRONT	7
6.6.2.	REAR	7
6.7.	DROP OUTS	7
6.8.	WHEELS	7

0. UPDATES

The development of frames, forks and components is a continuous running process. Therefore we strongly advise before reading this information sheet check our website for new updates.

1. GENERAL

1.1. DESCRIPTION

Superlight race bike, approximate weight: 950g. The oversized tube shape is engineered with the use of extremely high modulus carbon. This results in a very light frame, without compromising stiffness. The dual purpose internal cable routing uses the same holes for mechanical and electronic shifting, resulting in a very clean design without excess holes. Flex seat stays increase vertical compliance for additional comfort, without reducing lateral stiffness.

1.2. PART CODES

All the Helium frames have a particular part code composed by the letters "FRAHELRID...", added by 3 numbers. The three numbers, depending on the design and size of the frame. Due to the big amount of frames we don't list all the numbers but you can contact your local dealer for more information if needed.

2. MATERIAL

Used frame materials:

- 24 ton High Modulus Carbon
- 30 ton High Modulus Carbon
- Stainless steel (drop out protection plates)

3. WEIGHT

3.1. FRAME

SIZE	WEIGHT (*)
XS	-
S	-
M	880 GRAMS
L	-
XL	-

(*) Weight of unpainted frame, real weight may differ from the weight mentioned above by $\pm 10\%$.

3.2. FORK

The weight of the 4ZA Helium fork is around 340 g (*)

(*) Weight of unpainted fork, real weight may differ from the weight mentioned above by $\pm 10\%$.

4. GEOMETRY

SIZE	A	B	C	C'	D	E	F	G	H	I	J*	S	R
XS	440	480	510	525	130	74	72	405	68	974	740	530	375
S	470	510	530	545	145	73,5	73	405	66	977	750	545	385
M	500	540	550	565	175	73	73,5	405	66	990	780	575	390
L	530	570	570	585	205	72,5	73,5	408	63	1003	810	602	400
XL	560	600	585	600	230	72,5	74	408	63	1012	840	625	405

(*) J: Stand over height

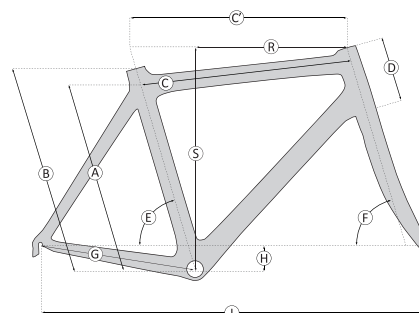

5. CABLE ROUTING

5.1. COMPATIBILITY

The Helium is compatible for:

- Mechanical groupsets
- Electronical groupsets: Shimano Di2 & Campagnolo EPS

5.2. MECHANICAL CABLE ROUTING

Below you can find the parts needed for a mechanical groupset:

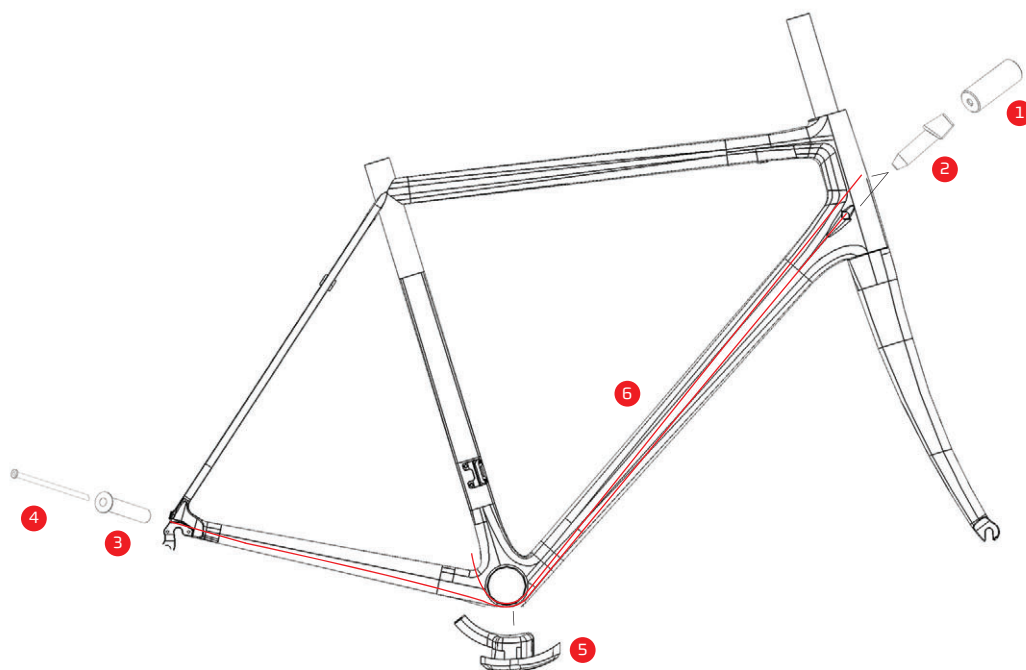

NO.	PART	PART CODE	QUANTITY
1	END CAP, SHIFTER CABLE	CABSTIJAG002	2
2	CABLE STOPPER	FRPSTORID006	2
3	REPLACEABLE INTERNAL CABLE STOPPER	FRPSTORID007	1
4	REPLACEABLE INTERNAL CABLE LINER	CABSTIRID001	1
5	CABLE GUIDE	CBGR CERID008	1
6	CLOSED GROMMET 10MM	FRPGROJAG007	1

5.3. ELECTRONIC CABLE ROUTING

Below you can find a drawing of the parts needed for an electronic groupset:

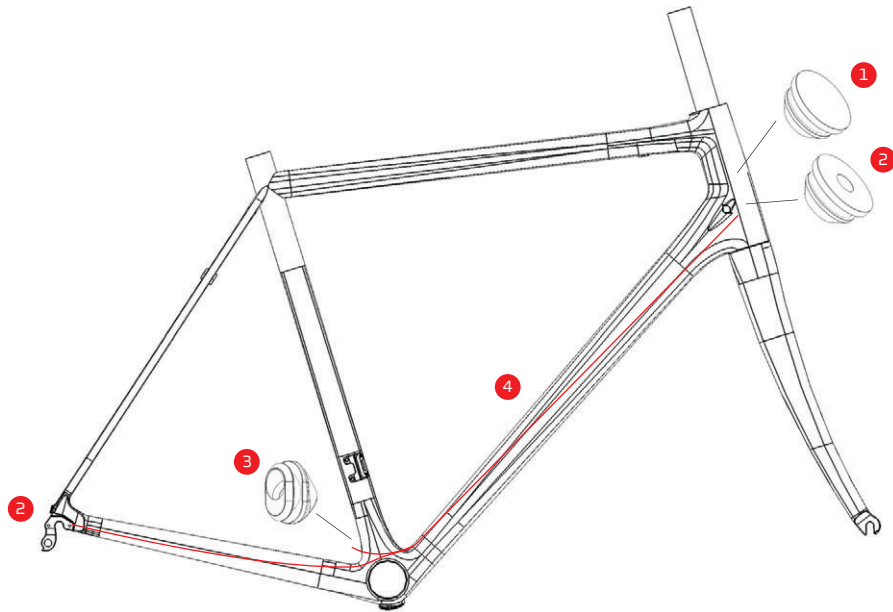

NO.	PART	PART CODE	QUANTITY
1	CLOSED GROMMET	FRPGROJAG002	1
2	OPEN GROMMET	FRPGROJAG003	2
3	DI2 GROMMET	FRPGRORID001	1
4	OPEN GROMMET 10MM	FRPGROJAG008	1

Battery mount position:

- The battery has to be mounted below the bottle cage on the down tube.

6. PARTS

6.1. FORK

The standard fork, used for a Helium, is the 4ZA Helium fork.

6.1.1. MATERIAL

- Fork legs: Carbon
- Steerer tube: Carbon

6.1.2. DIMENSIONS

- Steerer tube length: 300 mm
- Headset: 1 1/8" upper ring – 1 1/4" lower ring
- Fork rake: 45 mm
- OLD (OverLock nut Distance): 100 mm

6.1.3. WHEELS

The fork is developed for 700C race wheels with a build in width of 100 mm and a quick release system with a maximum diameter of 9 mm.

6.1.4. PART CODES

All the 4ZA Helium forks have a particular part code composed by the letters “FORCFR4ZA...”, added by 3 numbers. The three numbers, depending on the design. Due to the big amount of forks we don’t list all the numbers but you can contact your local dealer for more information if needed.

6.2. HEADSET

45° Semi oversized angular contact bearing:

- Lower bearing: 1 1/2”
- Upper bearing: 1 1/4”

Recommended headset:

RIDLEY PART CODE	TYPE	BRAND
HSERACFSA007	NO.44	FSA

6.3. SEAT POST

The Helium is developed to use a 27,2 mm seat post.

6.4. BOTTOM BRACKET

The bottom bracket is designed for press fit 30 cups with a diameter of 46 mm and width of 68 mm.

Below bottom bracket cups are being used for the standard assembled bikes.

PART CODE	BRAND	DESCRIPTION	COMPATIBLE CRANKSETS
BBRPF3SRA001	SRAM	PRESS FIT 30 CUPS	SRAM PRESS FIT 30 CRANKSETS
BBRPF3SRA002	SRAM	PRESS FIT 30 TO BSA 68 ADAPTER	SRAM BSA 68 CRANKSETS SHIMANO BSA 68 CRANKSETS
BBRPF3CAM002	CAMPAGNOLO	ULTRA TORQUE™ OS-FIT™ INTEGRATED CUPS BB30 68X46	CAMPAGNOLO ULTRA TORQUE CRANKSETS
BBRPF3CAM003	CAMPAGNOLO	POWER TORQUE™ OS-FIT™ INTEGRATED CUPS BB30 68X46	CAMPAGNOLO POWER TORQUE CRANKSETS

6.5. BRAKES

The Helium is suited for most standard brakes, available in the market.

6.6. DERAILLEUR

6.6.1. FRONT

The frame is provided with a braze on mount.

6.6.2. REAR

The hanger, used for the Helium is the HANRCERID033.



6.7. DROP OUTS

The carbon drop outs have stainless steel inserts for extra protection.

6.8. WHEELS

The frame is developed for 700C race wheels with a build in width of 130 mm and a quick release system with a maximum diameter of 9 mm.